



Single Wall Construction



- UL Listed in the US & Canada
- Flanged Nut & Bolt Construction
- Lowest Build Cost
- Fastest Build Time
- Virtually Unlimited Build Configurations
- Integrated Safety Features

Double Wall Construction



- UL Listed in the US & Canada
- Insulated Double Wall Panels
- 'Best In Class' Inner & Outer Showroom Finish
- Effective Acoustic Barrier
- Virtually Unlimited Build Configurations
- Integrated Safety Features

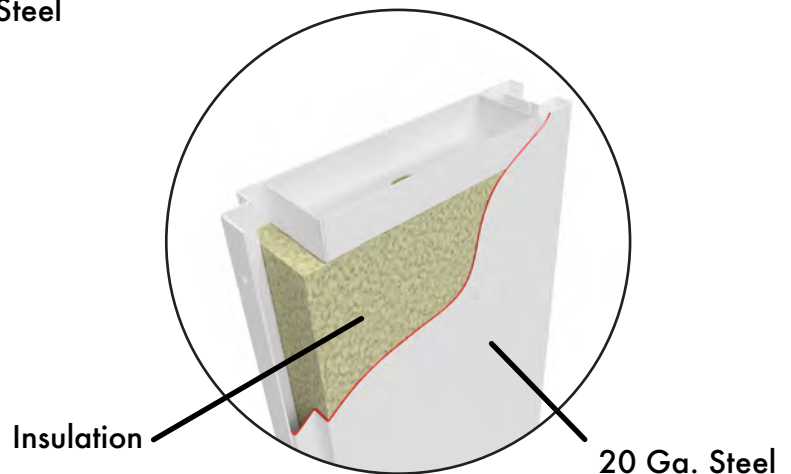
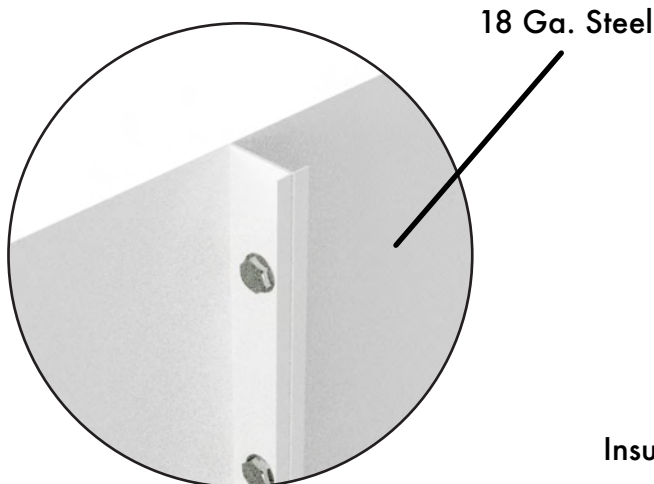



Podtronix UL Certified Build In Place Modular Pre-Fabricated CID1 Enclosures

Single Wall Enclosures



Double Wall Enclosures

